

Contents

	Page
1. Safety instructions	18
2. Description of the pressure cooker	20
3. The vitavit pressure cooker safety systems	21
4. About the pressure cooker	21
5. How the pressure cooker works	22
6. Before using for the first time	22
7. Basic information	22
8. The pressure cooking process	25
9. Care instructions	27
10. Questions and answers	28
11. Replacement parts	30
12. Cooking times	32
13. The Fissler warranty	33

Dear Customer,

Congratulations on your new Fissler pressure cooker! It will enable you to cook foods quickly, yet gently. You will be saving up to 70% of the usual cooking time and up to 50% of the energy you would normally need – without sacrificing vitamins or natural flavor. The foods cooked in your pressure cooker will be healthful and delicious.

These Instructions for Use will tell you about the various functions and design details which make it easy and safe for you to cook in your pressure cooker. You will soon know all about it.

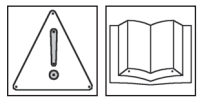

Please follow the Instructions for Use very carefully, to prevent problems which might result from improper handling. Remember that the cooker is under pressure when it is in operation.

We hope that you will enjoy cooking healthful and nutritious foods with your Fissler pressure cooker.

Sincerely,

Your Fissler Company



This product complies with the provisions of EU Directive 97/23/EC on pressure equipment. Conformity to this Directive is indicated by the CE marking.

1. Safety instructions

- Read the Instructions for Use carefully before using your pressure cooker for the first time. Do not permit anyone who is not familiar with these Instructions to use the cooker.
- Keep children away from the pressure cooker when it is being used.
- Only use the pressure cooker for the purposes described in the Instructions for Use.
- Never place the pressure cooker or pressure skillet in the oven, as this would destroy plastic and rubber parts and the safety mechanisms. Do not cover the pressure skillet or pressure cooker when deep-frying.
- Only use the pressure cooker with the heat sources which are described in the Instructions for Use (see Chapter 2).
- Pressure cookers are not to be used for medical purposes, especially not as sterilizers, as pressure cookers are not designed to reach the temperatures necessary for sterilization.
- Before using your pressure cooker, and each time you use it, check to make sure that the safety mechanisms are not damaged or dirty (see Chapter 7).
- Do not alter the safety mechanisms, except for the maintenance measures described in the Instructions for Use. Do not repair or oil the valves! Use only original Fissler replacement parts (see Chapter 11), to ensure that your pressure cooker will function properly and safely.
- Make sure that parts which wear out, such as the rubber gasket, O-ring for the valve base, and O-ring for the Euromatic, are replaced after 1-2 years at the latest by Fissler original replacement parts. Replace parts which show discolorations, have cracks or other damage, or do not fit correctly with Fissler original replacement parts before using the pressure cooker again.
- Make sure that you only use your Fissler pressure cooker with the Fissler pressure cooker lid for the same model.
- Never use your pressure cooker without adding liquid, as this could result in damage from overheating to the cooker and the burner. Adhere strictly to the following content amounts:
Minimum: 1/4 liter (2 cups) of liquid.
Maximum: 2/3 of the volume of the pressure cooker. For foods which foam or rise (e.g. rice, legumes, broths, or dried vegetables), 1/2 of the volume of the cooker.
Use the volume indicator inside the cooker and additional information in Chapter 7.
- Pressure cookers are under pressure when in use! Not adhering to the Instructions for Use can lead to burns and scalding. Make sure that the cooker is properly closed before it is heated up (see Chapter 7).

- Keep an eye on the pressure cooker while cooking, especially the indicator rod. Regulate the energy level so that the indicator rod does not rise above the desired cooking setting. In this case, if the energy level is not decreased, steam will escape through the valve. Cooking times will change, and a total loss of liquid can result in damage to the cooker and burner.
- Move the pressure cooker very carefully when it is under pressure. Do not touch the hot outer surfaces of the pressure cooker, as you could burn yourself by doing so! Only touch the handles when cooking, and use potholder gloves when necessary.
- Pressure cookers must be shaken before opening. This will prevent pockets of steam which might be caught within the food from splattering up when the pressure cooker is opened and scalding you. Do not cook applesauce or stewed fruits in a pressure cooker.
- Never try to force the pressure cooker open. Do not open it before you are certain that the steam inside has been expelled completely. Follow the instructions for opening the cooker (Chapter 8).
- Always keep your hands, head and body out of the danger zone when releasing steam from the pressure cooker! Be particularly careful about this when depressurizing with the safety slide.
- If you have cooked meat with skin (e.g. tongue) or sausage with casing which can swell when under pressure, do not pierce the skin as long as it is swollen. This could result in scalding!
- If the pressure cooker – or any of its parts – is damaged or does not function as described in the Instructions for Use, do not use the pressure cooker. Get in touch with your Fissler retailer or Fissler Customer Service immediately.
- Feel free to contact your Fissler retailer or Fissler Customer Service if you have any questions after reading the Instructions for Use. They will be pleased to help you.
- **Keep these Instructions for Use in a safe place.**

2. Description of the pressure cooker

See Fig. A

1. Fissler reach-through safety handle
2. Ergonomically designed safety slide for releasing steam and unlocking the cooker
3. Fissler Euromatic safety valve, located below the front part of the lid handle
4. Colored mark on the pot handle and stamp on the lid, for correct positioning of the lid
5. Main control valve for cooking setting selection, with safety mechanism
6. Indicator rod with marks for Gentle Setting I and Speed Setting II, located in the main control valve
7. Rubber gasket
8. Nut for firmly attaching the main control valve
9. Side grip for safe handling
10. Flame protection zone for handles for cooking on gas stoves
11. Base with integrated base stamp
Base for optimum heat absorption, distribution and storage

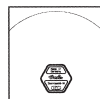

The Super Thermic base is suited for use on gas and electric stoves (solid burners or glass ceramic cooking surfaces).

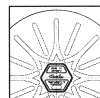

The Fissler CookStar all-stove base can also be used on gas and electric stoves, as well as induction stoves.



The base stamp contains the information below

See Fig. B

- a – Nominal capacity (not equal to usable capacity)
- b – Maximum permissible steam release pressure on the main control valve
- c – Date manufactured (calendar week/year)
- d – CE mark

12. Steamer set, with the perforated inset and tripod stand. (Pressure cookers are also available without steamer sets. Steamer sets can be purchased separately in stores.)

3. The vitavit pressure cooker safety systems

- Main control valve:
 1. with the indicator rod with markings for Gentle Setting I and Speed Setting II
 2. with cooking setting selection
 3. with pressure limitation function (If the selected cooking setting is exceeded, the main control valve automatically shuts off, at a maximum of 1.5 bar.)
- Fissler Euromatic:
 1. for automatic depressurizing of the cooker
 2. as a residual pressure block (When the safety slide is under pressure, it is blocked by the valve gate and cannot be opened. The pressure cooker can only be opened when it is completely pressureless.)
 3. with a safety function if the lid has been closed incorrectly (The valve does not seal the opening in the lid and thus does not permit pressure to build.)
 4. with a pressure limitation function (If there is a defect in the safety valve in the main control valve, the Euromatic automatically expels steam.)
- Rubber gasket
- Safety slide in the lid handle (works with Euromatic):
 1. to reduce pressure by releasing steam
 2. to unlock the lid before it is removed
- Bayonet locking system: ensures secure closure under pressure
- Reach-through safety handle for safe handling

4. About the pressure cooker

The vitavit pressure cooker makes perfect cooking results easy. Because of the high temperature in the pressure cooker, foods cook more quickly, while valuable vitamins and minerals are preserved. You save up to 70% of the usual cooking time and conserve up to 50% of the energy.

The cooking process begins automatically with the Fissler Euromatic, which expels the air from the pressure cooker. This means that the oxygen in the air, which can destroy important vitamins during cooking, cannot affect the vitamin content and aroma.

Using the main control valve, you can select the correct cooking setting for the food you are preparing.

At Gentle Setting I, for vegetables and other delicate foods, the temperature is approximately 109°C (about 0.4 bar). At Speed Setting II, for stews or meat dishes, it is approximately 116°C (about 0.8 bar). If the operating pressure for the selected setting in the pressure cooker is exceeded, steam is released automatically, at a maximum of 1.5 bar.

If vegetables are cooked in the perforated inset in steam instead of in water, most of the water-soluble vitamins are preserved.

5. How the pressure cooker works

Steam is formed in the closed cooker, which must always contain a certain amount of liquid. Air is expelled through the Fissler Euromatic, which then closes automatically.

The pressure in the cooker is built up, the temperature increases, and the indicator rod rises. Now you have to turn down the burner.

When the desired cooking setting has been reached, the actual cooking time begins. The indicator rod tells you how high the pressure is in the cooker at any given moment.

After the cooking time has elapsed, the pressure cooker must be depressurized completely (see Chapter 8). Only then can it be opened.

6. Before using for the first time

Wash the cooker and the lid thoroughly with dishwashing liquid. Then fill the cooker about halfway with water and boil at Speed Setting II, as described in these Instructions.

7. Basic information

Opening the cooker

See Fig. C

- Push the safety slide forward and
- turn the lid to the right (counterclockwise), until the marks on the lid and the safety handle are lined up, then lift the lid.

Before cooking

See Fig. D

Check to see that the indicator rod and valve gate can move freely, by gently pushing them upward. If they spring back easily, they will function properly.

See Fig. E

Check to see that the Fissler Euromatic (a) does not stick and is loosely in place in the lid and can move freely, by shaking it gently.

Check to see that the rubber gasket (b) is correctly in place in the lid.

What and how to cook in the pressure cooker and pressure skillet

You can use the pressure cooker for almost any kind of cooking: boiling, braising, steaming and browning.

Make sure that you always have the proper amount in the pressure cooker when it is

closed. The volume indicator inside the cooker will help you when adding liquids.

See Fig. F

Maximum volume:

The maximum volume for common foods is 2/3 of the cooker's capacity (upper mark). For foods which swell or foam (e.g. legumes, rice, noodles, broths, or dried vegetables), the volume may not exceed the lower mark. The cooker is then half full.

Minimum volume:

Please remember that the cooker must always contain at least 1/4 liter (2 cups) of liquid when cooking with or without the inset.

Important:

Always add enough liquid for steam to form, and make sure that the liquid in the pressure cooker does not evaporate completely. Never allow the cooker to "cook until dry," as the resulting overheating could damage the cooker (e.g. melt the base or damage the safety mechanisms) and the burner. In case of overheating, never remove the cooker from the burner. Simply turn off the burner and let the cooker cool down for a while on it. Have the pressure cooker checked by Fissler Customer Service before you use it again.

Cooking without the inset

Preparing meat

See Fig. G

1. Browning with fat:

- Turn the burner to medium high to high, and heat up the pressure cooker on it.
- Conduct the water drop test*. As soon as the cooker is hot enough, add fat.
- Brown the meat on the bottom of the cooker, reducing the heat if necessary. Then add the other ingredients as usual.
- Use the amount of liquid called for in your recipe, but at least 2 cups, or a good 1/4 liter.
- Close the cooker (see Chapter 7).
- Turn the burner to high.

2. Browning without fat:

- Turn the burner to medium high to high, and heat up the pressure cooker on it.
- Conduct the water drop test*.
- Place the meat in the hot pressure skillet or on the bottom of the pressure cooker, reducing the heat if necessary. If the meat "sticks" to the bottom, do not try to remove it. After about 2 minutes, it will loosen by itself.

If you have cooked meat with skin (e.g. tongue) or sausage with casing which can swell when under pressure, do not pierce the skin as long as it is swollen. This could result in scalding!

* Water drop test: When drops of water sprinkled onto the bottom of the cooker "dance around," the right temperature for frying has been reached.

Problem	Possible reason	How to correct problem
	The O-ring for the valve base is missing or damaged, or attached incorrectly.	Attach an intact O-ring correctly on the valve base.
Steam escapes around the main control valve.	This is normal. If a very large amount of steam escapes, however, this means that the temperature is too high.	Turn down the heat source – and then you can continue cooking as usual. Make sure that the indicator rod rises enough for the appropriate white ring to remain visible.
The Fissler Euromatic releases steam although the indicator rod has already risen.	The main control valve is dirty. The main control valve is damaged.	Turn off the burner and let the pressure cooker cool down. Take the main control valve apart and clean it. Turn off the burner and let the pressure cooker cool down. Replace the main control valve with a new replacement part.
The handles are loose.	The screws for the handles are not firmly tightened.	Tighten the screws with a screwdriver.

If you think something is wrong, turn the burner off and let the pressure cooker cool down.

Note:

If a part is defective, do not continue to use your pressure cooker. Replace it immediately. Use only original Fissler replacement parts (see Chapter 11). Any other replacement parts can affect how well and safely your cooker works. Make sure that your Fissler pressure cookers are only used with Fissler pressure cooker lids.

If you are unable to solve a problem or correct a defect, contact your Fissler retailer, the specialty department of your department store, or Fissler Customer Service.

10. Questions and answers

Problem	Possible reason	How to correct problem
The Fissler Euromatic expels steam longer than usual at the beginning.	The Fissler Euromatic valve or its O-ring is soiled or damaged.	Clean or replace these parts.
	The cooker is not closed properly.	Close cooker properly.
	The pressure cooker is not on a burner of the correct size.	Place the pressure cooker on a burner of the correct size.
	The heat source is not set at high.	Set the heat source at its highest setting.
No steam escapes from the Fissler Euromatic at the beginning.	There is too little liquid in the cooker.	Add the minimum amount (1/4 liter) of liquid.
Steam escapes at the edge of the lid.	The rubber gasket is not properly in place.	Insert the gasket properly.
	The rubber gasket is dirty or damaged.	Clean or replace the part.
The indicator rod does not rise.	The cooker is not closed properly.	Close the cooker properly.
	There is too little liquid in the cooker.	Add the minimum amount (1/4 liter) of liquid.
	The rubber gasket is damaged or hardened.	Insert a new gasket.
	The Fissler Euromatic or its O-ring is dirty or damaged.	Clean or replace the parts.
	The main control valve is not attached correctly and firmly.	Insert the main control valve correctly, and attach it firmly with the main control valve nut.

moved. To open, briefly release the slide and then push it all the way forward.

Opening during cooking

If you should need to open the pressure cooker during the cooking process, it must be depressurized first as described here. The lid will be hot, so be careful when opening and closing it! Only touch the handles, to avoid burning yourself.

Remember that you are interrupting the cooking process by opening the cooker. When you continue cooking, you must adjust the remaining cooking time and set the timer accordingly.

9. Care instructions

Wash the pressure cooker each time it is used. The pot and lid (including the Euromatic) can be washed by hand in the usual way or placed in the dishwasher. **Do not place the gasket or main control valve in the dishwasher, as they might be damaged by the dishwasher detergent.**

Use Fissler Stainless Steel Cleanser to remove water spots and to give your pressure cooker a brilliant shine. **Do not use steel wool or abrasive scouring powders or liquids.**

Cleaning the main control valve

See Fig. P

Each time you use the pressure cooker, you must remove the main control valve from the lid

and thoroughly wash all of its parts. You must take the main control valve apart to do so.

When putting the main control valve together again, follow the order shown in our drawing, to avoid improper assembly and safety risks which could thus result. Screw the main control valve into the lid from above it and the nut from below.

Food particles should be removed from the Euromatic safety valve under running water. It does not have to be removed to do so.

For a longer service life

The rubber gasket will last longer if you place the lid upside down on top of the pressure cooker after it has been washed.

Note:

Depending on how often you use your pressure cooker, you should replace the rubber gasket, the O-ring for the valve base, and the O-ring for the Euromatic every 1-2 years. In case of damage (tears or cracks, deformation on the edges, hardening or discoloration), these parts should be replaced immediately. Failure to do so may affect proper functioning and safety.

Important:

Never force the cooker open. It may only be opened if the indicator rod has fallen back into its socket completely and no more steam escapes when the safety slide is moved. Always shake the cooker before you open it. This will prevent pockets of steam which might be caught within the food from spattering up when the pressure cooker is opened. If you do not do so, you are in serious danger of suffering burns and scalding by the escaping steam and food.

There are three different ways of depressurizing the cooker:

1. Cool the cooker under running water

See Fig. N

Hold the cooker under the water tap and run gently flowing cold water over the lid – but not over the handle or main control valve – until the indicator rod has fallen back into its socket completely. Do not place the cooker in water.

Shake the cooker, and then move the safety slide. If steam still escapes, hold the cooker under the water tap again. Repeat this until no escaping steam can be seen or heard when the safety slide is moved. To open, briefly release the safety slide and then push it all the way to the front.

2. Release steam

See Fig. O

With the help of the safety slide, you can release the steam in intervals, little by little. When the indicator rod has fallen back into its socket completely, shake the cooker and move the safety slide. The remaining steam will then escape through the Euromatic. Repeat these steps until no escaping steam can be seen or heard when the safety slide is moved. To open the cooker, briefly release the safety slide and then push it all the way forward.

Important:

Do not use this depressurizing method when cooking soups, vegetables, stews, tongue, or other foods which are pulpy or which tend to rise or foam. Applesauce and stewed fruits should not be made in a pressure cooker. Failure to observe this may result in scalding!

3. Set aside to cool off

With this method, it takes quite a while for the temperature to fall. It should thus not be used for foods with very short cooking times, such as fish or vegetables, for they can easily become overcooked while the cooker is cooling down. It doesn't matter, however, if a pea soup cooks a little longer than planned.

When the indicator rod is no longer visible, shake the cooker gently and then activate the safety slide. Repeat this until no escaping steam can be seen or heard when the safety slide is

8. The pressure cooking process

To begin cooking

Place the pressure cooker on the proper burner:

Pressure cooker	Burner
Diameter	Diameter
18 cm	14,5 cm
22 cm	18 cm
26 cm	21 or 22 cm, 18 cm

Always begin with the burner at high. When using a gas stove, make sure that the flame does not go beyond the edge of the pot base.

When cooking begins, the temperature rises and the process begins automatically. Steam escapes from under the lid handle, taking with it the oxygen in the air, which can destroy vitamins and minerals. This process may take a few minutes. The Fissler Euromatic valve closes automatically. Shortly afterwards, the indicator rod begins to rise. The first white ring becomes visible.

Turn down the heat

- If you want to cook at Gentle Setting I (1st ring – *see Fig. L*), turn down the heat on your stove shortly before the first white ring be-

comes visible. The first white ring must remain visible during the entire cooking period.

- If you want to cook at Speed Setting II (2nd ring – *see Fig. M*), turn down the heat just about when the first white ring has become completely visible. The second white ring must remain visible during the entire cooking period.

If the indicator rod continues to rise after the first or second ring (depending on the setting selected) has become visible, you will hear a hissing sound, and the excess steam will escape through the main control valve. This means that the temperature is too high and the burner must be turned down, or else the liquid will evaporate completely.

The cooking time begins

The actual cooking period begins when the indicator rod has reached the desired setting. Cooking times can be found in the tables (see Chapter 12). These cooking times are only guidelines, however. The actual cooking time depends on the quality and size of the items being cooked, as well as personal taste. It is a good idea to use a kitchen timer, such as the magic timer.

End of the cooking time

When the cooking time has elapsed, remove the pressure cooker from the stove and depressurize it.

Preparing soups and stews

Soups and stews should always be cooked without the inset. The cooker must never be more than 2/3 full. In the case of foods which swell or foam a great deal, only half full. First place the soup in the cooker, leaving it uncovered, and bring to a boil two or three times, so that you can scoop off the foam, stir, and then close the cooker.

Do not prepare stewed fruits or applesauce in a pressure cooker! Disregarding this warning may result in scalding!

Cooking in the perforated inset

Vegetables, fish, and other delicate foods can be cooked in the perforated inset, with or without the tripod.

See Fig. H

Preparing vegetables and potatoes

- Pour a minimum of 2 cups (a good 1/4 liter) of liquid into the pressure cooker. If desired, add herbs, seasonings or wine.
- Place the trimmed vegetables in the perforated inset, then set it on top of the tripod in the cooker.
- Close the cooker.
- Turn the burner to high.

Preparing fish

After adding the minimum amount of liquid, cook the fish in its own juice at the bottom of the cooker, or else steam it in the perforated inset.

Cooking in the unperforated inset

Please remember that the unperforated inset may only be used together with the tripod (or the perforated inset).

Note: Replacement sets can also be purchased separately in stores.

Deep-frying in the pressure cooker

- For deep-frying in the pressure cooker, the cooker must always be open, without a lid. Only fill the cooker halfway, in order to prevent burns due to foaming oil or grease splatters. Make sure that you do not overheat the fat.

Closing the cooker

See Fig. I

Put on the lid so that the red dot on the pot handle and the circle on the lid are lined up. Press the safety slide forward while turning the lid.

See Fig. J

To close and lock, turn the lid in the direction shown by the arrow (clockwise) as far as possible, until you hear the safety slide click into place.

Selecting the cooking setting

See Fig. K









Turn the main control valve until the mark points toward the desired setting:

- Gentle Setting I means gentle cooking. It is especially suited for delicate foods like vegetables or fish.
- Speed Setting II means fast cooking. It is especially suited for foods which must be cooked longer, such as soups, meats or stews.





11. Replacement parts

Please note:





Depending on how often you use your pressure cooker, you should replace the rubber gasket, the O-ring for the valve base of the main control valve, and the O-ring for the Euromatic every 1-2 years. In case of damage (tears or cracks, deformation on the edge, hardening or discoloration), these parts should be replaced immediately. Failure to do so may affect proper functioning and safety.

Description	Diameter		Ordering number			
			Vitavit royal (black)	Vitavit carina (gray)	Vitavit blue dream (blue)	
Pot handle, Pressure cooker complete	18 cm		11 601 00 630	37 605 00 650	-	
	22 cm		11 631 00 630	37 635 00 650	14 633 00 650	
	26 cm		11 691 00 630	37 695 00 650	14 693 00 650	
	Pressure skillet		22 cm	11 631 02 630	-	-
			26 cm	11 691 04 630	37 695 04 650	14 693 04 650
Lid handle, complete	All sizes		11 631 02 660	37 635 00 660	14 633 00 660	
Profile strip	All sizes		11 631 00 240	11 631 00 240	11 631 00 240	
Side handle, Pressure cooker complete	18 cm		11 101 18 640	37 605 00 640	-	
	22 cm		11 631 00 640	37 635 00 640	14 633 00 640	
	26 cm		11 101 26 640	37 695 00 640	14 693 00 640	
	Pressure skillet		22 cm	11 631 02 640	-	-
			26 cm	11 101 26 640	37 695 00 640	14 693 00 640
Main control valve, complete, with valve insert	All sizes		11 631 01 700	37 643 00 700	14 633 00 700	
Cap for main control valve	All sizes		11 631 00 730	37 643 00 730	14 633 00 730	
Insert for main control valve, complete	All sizes		18 632 00 720	18 632 00 720	18 632 00 720	
Conical spring for indicator rod	All sizes		18 601 00 720	18 601 00 720	18 601 00 720	

F I S S L E R V I T A V I T [®]

Description	Diameter		Ordering number		
			Vitavit royal (black)	Vitavit carina (gray)	Vitavit blue dream (blue)
Base for main control valve, with nut and washer	All sizes		18 632 00 710	18 632 00 710	18 632 00 710
O-ring for valve base	All sizes		18 632 00 740	18 632 00 740	18 632 00 740
Euromatic incl. O-ring	All sizes		11 631 00 750	11 631 00 750	11 631 00 750
O-ring for Euromatic	All sizes		11 631 00 760	11 631 00 760	11 631 00 760
Rubber gasket	18 cm		38 617 00 205	38 617 00 205	38 617 00 205
	22 cm		38 667 00 205	38 667 00 205	38 667 00 205
	26 cm		38 687 00 205	38 687 00 205	38 687 00 205

The O-ring of the Euromatic is detached/attached on the inner side of the lid. Remove the lid handle and push the Euromatic through to the upper side of the lid, using your finger. This will make it easier to replace the O-ring. Make sure that the gasket lies completely in its groove.

Accessories	Diameter		Ordering number
Perforated inset	18 cm		21 625 02 610
	22 cm		21 633 04 610
	26 cm		21 656 06 610
Unperforated inset	22 cm		21 633 04 620
	26 cm		21 656 06 620
Tripod	18 cm		21 625 02 630
	22 cm		18 621 04 630
	26 cm		21 656 08 630
Socket lid	18 cm		11 601 18 200
	22 cm		11 631 22 200
	26 cm		11 691 26 200

All replacement parts can be purchased from your Fissler retailer or in the specialty departments of department stores. Or else contact Fissler Customer Service directly.

12. Cooking times

The cooking times shown here are intended as guidelines and apply to an amount suitable for 4 portions, cooked at Speed Setting II. Using Gentle Setting I will increase the cooking time by about 50%, but this will still be far less than would be necessary with conventional cooking. The exact cooking times depend upon the size and freshness of the food. It won't take long for you to develop a feeling for this.

<u>Meat</u>	<u>Min.</u>
Beef Stroganoff.....	7
Chicken (depends on size/weight)	20-25
Collared beef	15-20
Goulash	15-20
Ham, boiled.....	30-35
Ham, roast	20-25
Pork knuckle	30-40
Pork roast	25-30
Pork shank.....	25-35
Ribs with sauerkraut and potatoes	10-12
Roast beef	40-50
Sauerbraten.....	30-35
Turkey leg.....	25-35
Veal roast, rabbit	15-20
Veal fricassee	5

<u>Fish/Game</u>	<u>Min.</u>
Fish in white wine with potatoes.....	6-8
Haddock	4-6

Leg of venison	25-30
Steamed fish with potatoes	6-8

<u>Stews</u>	<u>Min.</u>
Cabbage stew	15
Irish stew	20
Lentils (presoaked) with bacon and potatoes	3-5
Serbian meat and rice stew with mushrooms	8-10

<u>Soups</u>	<u>Min.</u>
Beef broth (depends on meat weight).....	35-40
Chicken soup (depends on size/age of chicken)	25-35
Goulash soup	10-15
Minestrone	8-10
Pea soup (not presoaked)	20-25
Potato soup	5-6
Pot-au-feu	20-25
Rice soup	6-8
Semolina soup	3-5
Tomato soup with rice	6-8
Vegetable soup.....	4-8

<u>Vegetables</u>	<u>Min.</u>
Beets.....	15-25
Black salsify	4-5
Cabbage (red or white), kale	8-10
Cauliflower	2-3
Cauliflower, whole.....	4-6

Mushrooms.....	6-8
Peas.....	3-4
Peppers, stuffed	6-8
Potatoes, jacket	8-10
Potatoes, peeled.....	6-8
Sauerkraut	2-3
Vegetables, mixed	5-6

Legumes **Min.**

Peas, whole, unshelled, not presoaked	45-55
Peas, whole, unshelled, presoaked	12-15
Peas, shelled, whole, not presoaked	15
Large lentils, unshelled, not presoaked	10-15
Large lentils, unshelled, presoaked	3-5
White beans, germinated.....	3-5

Grains **Min.**

Raw brown rice, oats, wheat, barley, rye, spelt, all approx.....	9
(Depressurize cooker and allow to puff with closed lid)	15
Buckwheat, millet, both.....	6
(Do not allow to puff after cooking)	

13. The Fissler warranty

Warranty

For all Fissler pressure cookers and pressure skillets, Fissler grants the owner a three-year warranty on all functional parts (excluding parts which are subject to wear, such as the rubber gasket, the O-ring for the Euromatic, and the O-ring for the base).

Improper use will result in a cancellation of the warranty.

10-year availability guarantee for replacement parts

All functional parts of your pressure cooker – from the rubber gasket to the complete lid handle – can be obtained, even after your warranty has elapsed, from retailers who carry Fissler products, from specialty departments in department stores, or directly from:

Fissler GmbH

Customer Service Department
D-55768 Hoppstädten-Weiersbach
Germany
Tel. +49 6781/403-556